



6000X-HD INSTRUCTION MANUAL

6000X-HD

Welding helmet with 3 memory functions and true color ADF

WARNING

Read and Understand All Instructions Before Using the Equipment.

SAFETY WARNINGS

The auto-darkening helmet with improved High Definition Filter Optics delivers a new generation of face and eye protection. Advanced integrated technology such as LCD, optoelectronics detection, solar power, and microelectronics are coordinated to produce one of the safest, fastest and most reliable auto-darkening helmets available.

The auto-darkening helmet not only can efficiently protect operator's eyes and face from sparks, spatter, and harmful radiation under normal welding conditions, but also can make both hands free and strike arc accurately resulting in increased efficiency and improved quality welds. It may be widely used for various welding, cutting, spraying and arc gouging, etc.

- This auto-darkening helmet is not suitable for "overhead" welding, laser welding/cutting, or oxyacetylene welding/cutting applications.
- This helmet will not protect against explosive devices or corrosive liquids. Machine guards or eye splash protection must be used when these hazards are present.
- Impact resistant, primary eye protection, spectacles or

goggles that meet current ANSI specifications must be worn at all times when using this welding helmet.

- Avoid work positions that could expose unprotected areas of the body to spark, spatter, direct and/or reflected radiation. Use adequate protection if exposure cannot be avoided.
- Do not make any modifications to either the ADF cartridge or helmet, other than those specified in this manual.
- Do not use any replacement parts other than those specified in this manual. Unauthorized modifications and replacement parts will void the warranty and expose the user to the risk of personal injury.
- Do not immerse this helmet in water because this model is not waterproof.
- Do not use any solvents on any ADF or helmet components.
- The recommended operating temperature range for this ADF cartridge is -10°C~65°C (14°F~149°F). Do not use this device beyond these temperature limits.

Failure to follow these warnings and/or failure to follow all of the operating instructions could result in severe personal injury.

CONTENTS

1. Specifications
2. Operation Instruction
3. True Color
4. Maintenance
5. Trouble Shooting
6. Warranty & Replacement Parts
7. Parts List
8. Recommended Shade Numbers

1. SPECIFICATIONS

The specifications of the 6000X-HD helmet are the following:

1. ADF Cartridge size	114 x 133 x 9.5 mm (4.5" x 5.25")
2. LCD Viewing area	100 x 83.4 mm (3.94" x 3.28")
3. Light State Shade	DIN 4

4. Dark Variable Shades	DIN 5-9 / 9-13
5. UV/IR Protection	Up to DIN 15 at all times
6. Switching time (light to dark)	0.08ms
7. Delay time (dark to light)	Adjustable (1-5 for 0.1-0.9s)
8. Sensitivity	Adjustable (1-5 for low-high)
9. Arc Sensors	4
10. Grind Function	Yes
11. Memory Settings	3
12. Power Supply	Solar and CR2450 battery
13. Operating Temperature	-10°C~65°C (14°F~149°F)
14. Inside PC lens	106 x 89.5 x 1 mm
15. Outside PC lens	114 x 133 x 1 mm (4.5" x5.25")
16. Standards	CE EN379, ANSI Z87.1, CSA Z94.3, AS/NZA
17. Warranty	2 years

2. OPERATION INSTRUCTION

BEFORE USE

- Check for light tightness and check the inside & outside protection lens are clean and that no dirt is covering the sensors on the front of the auto-darkening-filter (ADF) cartridge.
- Make sure the protection films on both inside & outside protection lens are removed.
- Inspect all operating parts for signs of wear or damage. Any scratched, cracked, or pitted parts should be replaced immediately.

SCREEN ICON EXPLANATION



	1. Battery status
	2. Welding indication
	3. Grinding indication
	4. Shade range 5-9
	5. Shade range 9-13
	6. Sensitivity indication: 1 (low) to 5(high)
	7. Delay indication: 1 (short 0.1s) to 5 (long 0.9s)
	8. Shade reading
	9. Memory selection

A representation of the view is the following:



Note: Buttons on the left of the screen need to be pressed twice to start any settings. Otherwise they will not operate.

VARIABLE SHADE CONTROL

- If the Shade is in the range of 5~9, press WELD/GRIND button repeatedly until both icon 2 and icon 4 appear on the screen. Then press SHADE button repeatedly until the desired Shade shown in Icon 8.
- If the Shade is in the range of 9~13, press WELD/GRIND button repeatedly until both icon 2 and icon 5 appear on the screen. Then press SHADE button repeatedly until the desired Shade shown in Icon 8.

Note: Choose an optimum Shade number for the required welding process or application (see Table 1). If this ADF does not darken when striking arc, stop welding immediately and contact our representative.

SENSITIVITY CONTROL

The responsive to different light levels in various welding processes can be adjusted in the range 1-5 (from low to high).

- Press the SENSITIVITY button twice to start the setting. The Icon 6 on the screen flashes (from 1 to 5). Repeatedly press the SENSITIVITY button until the desired level shown in Icon 6.
- Turn to 1 (low) : The photosensitivity changes to be lower. Suitable for high amperage welding and welding in bright light conditions (lamp light or sun light).
- Turn to 5 (high) : The photosensitivity changes to be higher. Suitable for low amperage welding and using in poor light conditions and suitable for using with steady arc process such as TIG welding.

Under normal use, a higher sensitivity setting is recommended.

DELAY CONTROL

The length of time delay for the ADF returns to light state after welding can be adjusted in the range 1-5 (for 0.1~0.9s). The time delay is for protection of welder's eyes from strong residual rays after welding.

- Press the DELAY button twice to start the setting. The Icon 7 on the screen flashes (from 1 to 5). Repeatedly press the DELAY button until the desired length of time delay shown in Icon 7.
- Turn to 1 (0.1s) : The time the ADF lighten after welding to be shorter. The shortest time is about 0.1s depending upon welding point temperature and shade set. This setting is ideal for track welding or production welding with short welds.
- Turn to 5 (0.9s) : The time the ADF lighten after welding to be longer. The longest time is about 0.9s depending upon welding point temperature and shade set. This setting is ideal for welding at high amperage where there is an afterglow from the weld.

GRIND SELECTION

- Press WELD/GRIND button repeatedly until icon 3 appears on the screen and the red light beside the button flashes. Additionally, icon 8 will show shade 4.

Note: Do not weld in the Grind mode, the ADF will not darken.

MEMORY SETTING

3 most frequently used setting can be stored and reactivated easily by using the 3 MEMORY buttons on the right side of the screen.

Upon use of this helmet, the last ADF settings will be stored automatically (stored about 5 minutes after). The next time when you start to weld, the last settings will be automatically re-activated.

- If you want to store a completed welding setting, press and hold one of the memory buttons and stop pressing when the icon 9 stops flashing.
- To activate the stored memory, press the memory button.

Note: Only in welding status you can activate the memory. Change to welding if you are currently using the grinding function.

HEADGEAR ADJUSTMENTS

Because the shapes of man's heads vary from person to person. The work positions and the observing angles are different.

Operator may adjust the headband in 5 parameters:

1. Select eye level by Headband adjusting buttons.
2. Select view angle by Segmental positioning plate.
3. Adjust head size perimeter by pushing and turning the headband tightness adjusting knob.
4. Select eyes distance from ADF by adjusting Headgear screws to 1 of the 5 slots on the Headgear slider. Make sure both sides are equally positioned for proper vision.
5. Select the height of the headgear by adjusting the Block washers up or down on the Block washer adjustment.

BATTERY INDICATOR

Icon 1 indicates the battery status. Replace the battery when it is low, otherwise, the ADF switching time will become slower and shade accuracy will be compromised.

POWER SUPPLY AND REPLACE THE BATTERY

The power of the auto-darkening helmet is provided by solar cells and 1pcs of CR2450 lithium battery.

When change the battery, open the Battery holder at the side of the ADF and replace the battery.

3. TRUE COLOR

The auto-darkening helmet is a True Color welding helmet. With advanced True Color technology, the users can weld with improved clarity due to new complex coating technology, grind with precision while in grind mode and finally see the job performance in the light state in the full spectrum of colors. There is no need to remove the helmet to see clearly! Results are enhanced the weld quality, increased efficiency and improved safety because the users can see more.

4. MAINTENANCE

The auto-darkening helmet needs little maintenance. Use a clean, soft piece of cloth moistened with soft soap / pure alcohol / commercial disinfectant to wipe the inside and the outside of the helmet.

Store the product in a dry environment.

Note: Do not immerse the helmet or ADF in water directly.

5. TROUBLE SHOOTING

Trouble	Remedy
The ADF does not darken when welding.	<ul style="list-style-type: none"> • Stop welding or cutting immediately. • Make sure the sensors are facing the arc and no obstructions. • Check the mode that is on WELD not GRIND. • Review sensitivity recommendations and adjust sensitivity if possible. • Replace the battery if necessary.
The ADF stays dark after welding or there is no arc present.	<ul style="list-style-type: none"> • Adjust the sensitivity to the lower level (level 1). • If the welding place is extremely bright, it is recommended to reduce the surrounding light level.
The ADF switching during the welding.	<ul style="list-style-type: none"> • Increase the sensitivity if possible. • Make sure the sensors are facing the arc and no obstructions. • Increase Delay 0.1 – 0.3 second may also reduce switching.
Inconsistent shade number on the corner of ADF.	<ul style="list-style-type: none"> • It is a natural feature and will not be dangerous for the eyes. • In order to get a maximum comfort, try to keep an view angle at around 90°.

6. WARRANTY & REPLACEMENT PARTS

WARRANTY

The auto-darkening helmets are warranted for 2 years from the date of purchase. The duration of use depends on various factors such as use, cleaning storage and maintenance. Frequently inspections and replacement if it is damaged are recommended.

REPLACEMENT PARTS

13.01.051	Outer protection lens
13.01.052	Inner protection lens
13.01.011	Headgear complete (HG2003)
13.01.012	Sweatband Headgear
13.06.200	Auto darkening filter 6000X-HD

7. PARTS LIST

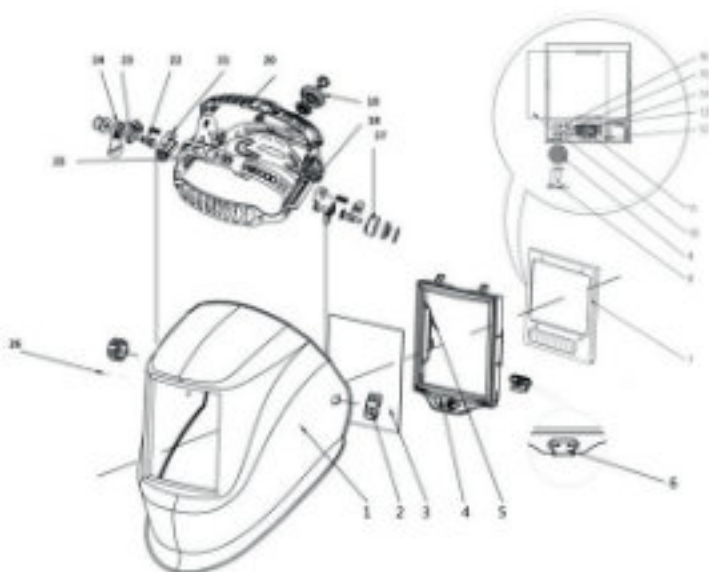

1. Helmet shell
2. Headgear screw
3. Outer protection lens
4. ADF cradle
5. Magnifying lens holder
6. Cradle lock
7. Auto filter
8. Battery holder
9. Battery
10. Inner protection lens
11. ADF setting panel
12. Memory buttons(3)
13. Weld/Grind button
14. Delay button
15. Sensitivity button
16. Shade button
17. Block washer(on left)
18. Headgear slider (with 5 slots)
19. Headband tightness adjusting knob
20. Headband adjustment(back and forth)
21. Block washer adjustment(up and down)
22. Headband screw(long, on right)
23. Block washer (on right)
24. Segmental positioning plate (on right)
25. Headband adjusting buttons
26. Positioning point for the segmental plate

8. RECOMMENDED SHADE NUMBERS

WELDING PROCESS	CURRENT AMPERES																						
	0,5	1	2,5	5	10	15	20	30	40	50	60	100	125	150	175	200	225	250	275	300	350	400	450
Covered Electrode					Shade 9		Shade 10		Shade 11			Shade 12				Shade 13		14					
MIG Plate Welding							Shade 10		Shade 11			Shade 12				Shade 13		14					
MIG Sheet Metal							Shade 10		Shade 11			Shade 12		Shade 13		Shade 14		15					
TIG			Shade 9		Shade 10		Shade 11		Shade 12		Shade 13		Shade 14										
MAG							Shade 10		Shade 11		Shade 12		Shade 13		Shade 14		Shade 15						
Arc Gouging									Shade 10		11		12		13		14		15				
Plasma Cutting									Shade 11		Shade 12		Shade 13										
Plasma Welding											13		14		15								

DIN EN 379: 2003 + A1:2009
 DIN EN 175: 1997-08
 DIN EN 166: 2002-04

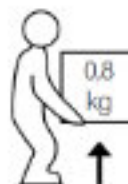
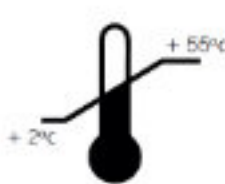
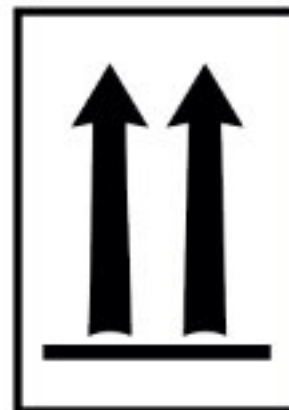

ATTENTION

if any of these conditions is not kept or followed, the warranty is automatically invalid.